

Diese Zeichnung darf ohne unsere Genehmigung weder vervielfältigt, noch dritten Personen zugänglich gemacht werden und bleibt unser Eigentum. Zuwiderhandlung ist strafbar.  
All rights strictly reserved. Reproduction or issue to third parties in any form whatever is not permitted without written authority from the proprietor. Violation is punishable.

Gesamte und digital verteilte Zeichnungen benötigen zur Freigabe keine Unterschrift!  
Scanned and digitally distributed drawings do not need a signature for the release!

Technische Änderungen vorbehalten!  
Technical modifications will be reserved.

Verteiler distributor  
Empfänger receiver  
SDH  
SDW

ECO-FLEX M (RAST 5) Messerleiste in THT-Einlöttechnik für waagerechtes Stecken, Rastfenster unten, erhöhte Variante für Außenrastarm, mit Zapfen, mit versetztem Rastloch im Kontakt  
ECO-FLEX M (RAST 5) Tab connectors in THT soldering technology for horizontal connections, raised version, for locking feature outside at bottom, with pegs, with staggered locking feature at contact

Raster: / pitch: 5mm Identifikator: / identification: MSVV\_9408-006\_A\_KF Blatt: / page: A

Fehlende Maße und Hinweise siehe separate Kundenzeichnung  
Missing dimensions and notes see separate customer drawing

  
**STOCKO CONTACT**  
GmbH & Co. KG

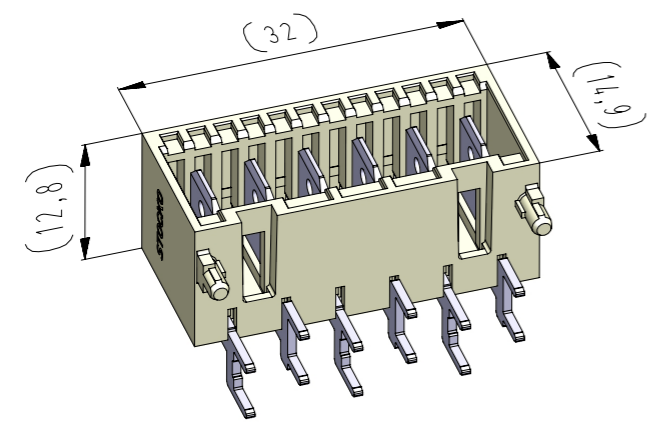

Lochbild (Bestückungsseite) / hole pattern (component side)

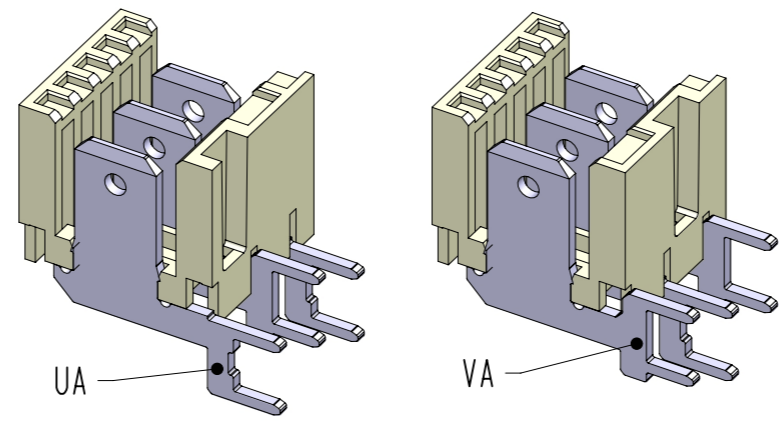
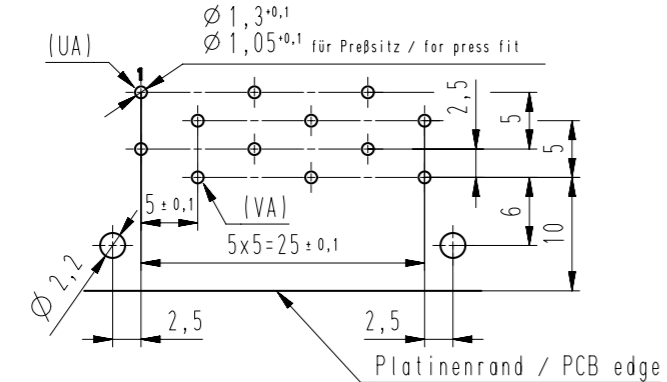

vereinfachte Darstellung einer möglichen Abart  
simplified representation of possible variation

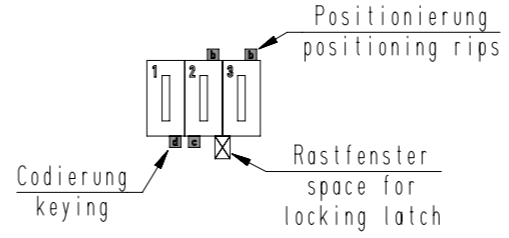

Beispiel Artikelbezeichnung:  
example part description:  
MSVV 9408-006-W01-CCC-MMM-NN

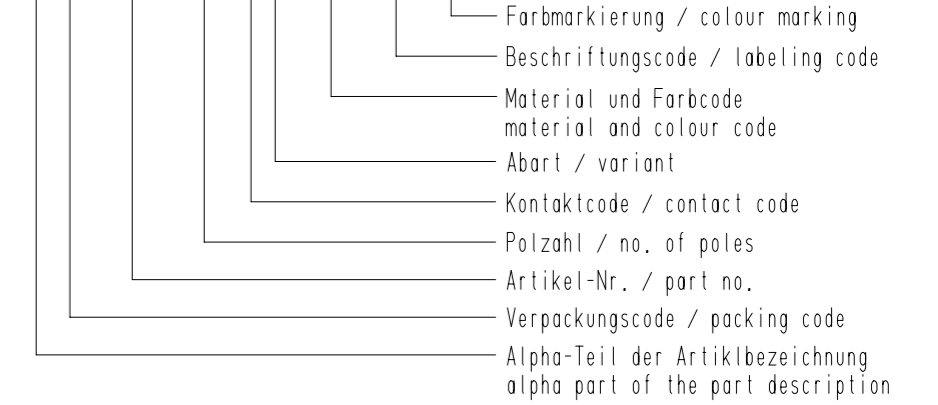

-VV-		
Verpackungscode / packing code		
VV	Verpackungsart / packaging	Bemerkung remark
LO	lose, geschüttet slack pouring	WN 50.202
EM	Einzelmagazine single magazine	WN 50.202

-W-			
Kontaktcode / contact code			
W	Kontakt Artikel-Nr. contact part no.	Material material	Veredelung plating
0	UA = RM 6147.051 P 0,8-6,3	CuZn	Sn
	VA = RM 6148.051 P 0,8-6,3		

Artikelbezeichnung part description	Anzahl der Kontakte number of contacts	Bestückung / loading						Codierungsvariante siehe Tabelle coding peg variant see chart MH 8420-006	Rastfenster zwischen den Kammern space for locking latch between chambers Bemerkung / remark		
		1	2	3	4	5	6				
MSVV 9408-006-026-CCC-MMM-NN	6	UA	VA	UA	VA	UA	VA	26	<input checked="" type="checkbox"/>	<input checked="" type="checkbox"/>	<input checked="" type="checkbox"/>
									<input type="checkbox"/>	<input type="checkbox"/>	<input type="checkbox"/>
									<input type="checkbox"/>	<input type="checkbox"/>	<input type="checkbox"/>
									<input type="checkbox"/>	<input type="checkbox"/>	<input type="checkbox"/>
									<input type="checkbox"/>	<input type="checkbox"/>	<input type="checkbox"/>
									<input type="checkbox"/>	<input type="checkbox"/>	<input type="checkbox"/>
									<input type="checkbox"/>	<input type="checkbox"/>	<input type="checkbox"/>
									<input type="checkbox"/>	<input type="checkbox"/>	<input type="checkbox"/>
									<input type="checkbox"/>	<input type="checkbox"/>	<input type="checkbox"/>
									<input type="checkbox"/>	<input type="checkbox"/>	<input type="checkbox"/>
									<input type="checkbox"/>	<input type="checkbox"/>	<input type="checkbox"/>
									<input type="checkbox"/>	<input type="checkbox"/>	<input type="checkbox"/>
									<input type="checkbox"/>	<input type="checkbox"/>	<input type="checkbox"/>
									<input type="checkbox"/>	<input type="checkbox"/>	<input type="checkbox"/>
									<input type="checkbox"/>	<input type="checkbox"/>	<input type="checkbox"/>
									<input type="checkbox"/>	<input type="checkbox"/>	<input type="checkbox"/>
									<input type="checkbox"/>	<input type="checkbox"/>	<input type="checkbox"/>

Artikelbezeichnung part description	Anzahl der Kontakte number of contacts	Bestückung / loading						Codierungsvariante siehe Tabelle coding peg variant see chart MH 8420-006	Rastfenster zwischen den Kammern space for locking latch between chambers Bemerkung / remark		
		1	2	3	4	5	6				
									<input type="checkbox"/>	<input type="checkbox"/>	<input type="checkbox"/>
									<input type="checkbox"/>	<input type="checkbox"/>	<input type="checkbox"/>
									<input type="checkbox"/>	<input type="checkbox"/>	<input type="checkbox"/>
									<input type="checkbox"/>	<input type="checkbox"/>	<input type="checkbox"/>
									<input type="checkbox"/>	<input type="checkbox"/>	<input type="checkbox"/>
									<input type="checkbox"/>	<input type="checkbox"/>	<input type="checkbox"/>
									<input type="checkbox"/>	<input type="checkbox"/>	<input type="checkbox"/>
									<input type="checkbox"/>	<input type="checkbox"/>	<input type="checkbox"/>
									<input type="checkbox"/>	<input type="checkbox"/>	<input type="checkbox"/>
									<input type="checkbox"/>	<input type="checkbox"/>	<input type="checkbox"/>
									<input type="checkbox"/>	<input type="checkbox"/>	<input type="checkbox"/>
									<input type="checkbox"/>	<input type="checkbox"/>	<input type="checkbox"/>
									<input type="checkbox"/>	<input type="checkbox"/>	<input type="checkbox"/>
									<input type="checkbox"/>	<input type="checkbox"/>	<input type="checkbox"/>
									<input type="checkbox"/>	<input type="checkbox"/>	<input type="checkbox"/>

-CCC-			
Material und Farbcode material and colour code			
Materialinformation siehe Kundenzeichnung material data see customer drawing			
Leergehäuse / housing: MH 9406-...			
WN 14.0617.01 (PA66-GF25)	WN 14.0634.01 (PA66-GF25)		
Code-Nr. code no.	Farbe colour	Code-Nr. code no.	Farbe colour
118	zinkgelb / zinc yellow	960	natur / nature
121	ropsgelb / rope yellow		
314	altrosa / antique pink		
512	lichtblau / light blue		
518	türkisblau / turquoise blue		
605	moosgrün / moos green		
701	silbergrau / silver grey		
905	schwarz / black		
960	natur / nature		

-MMM-		
Beschriftungscode nach Kundenwunsch labeling code acc. to the customer		
Code-Nr. code no.	siehe WN see WN	Farbe colour
000	----	ohne Beschriftung without labeling
S**	30.76	Standard / standard

-NN-		
Code-Nr. für Farbm Markierung siehe WN 30.83 code no. for colour marking see WN 30.83		
Code-Nr. code no.	Farbe / colour	
00	ohne / without	

8	Material WN 14.0634.01 mit Materialcode -960- hinzu	04.03.22	U0013643
7	Material und Farbcode 627, 715, 721 ungültig und 121 hinzu	11.09.20	U0013643
index	Änderung / modification		Name
	Datum date	Name name	Projektleiter project manager
erstellt prepared	18.05.10	U0001349	D.M.
			<b>MSVV 9408-006</b>

Beachten Sie die allgemeinen Sicherheits- und Verarbeitungshinweise für Steckverbinder und Kontakte: <http://www.stocko.de/catalog-pdf/sicherheitshinweise.pdf> Respect general safety and processing information for connectors and contacts: <http://www.stocko.de/catalog-pdf/safety-information.pdf>