

ECO-FLEX M (RAST 5) Messerleiste in THT-Einlöttechnik für senkrechtes Stecken, dual-line
 ECO-FLEX M (RAST 5) Tab connectors in THT soldering technology for vertical connections, dual-line

Raster: / pitch: 5mm
 Identifikator: / identification: MSVV_9401-009_A_KF
 Blatt: / page: A

Fehlende Maße und Hinweise siehe separate Kundenzeichnung
 Missing dimensions and notes see separate customer drawing

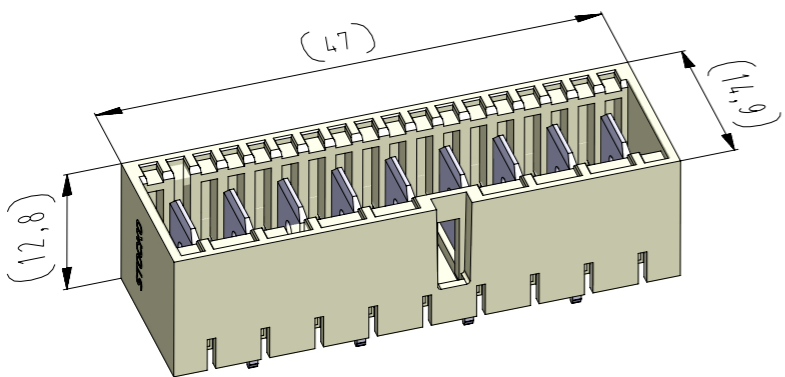

Lochbild (Bestückungsseite) / hole pattern (component side)

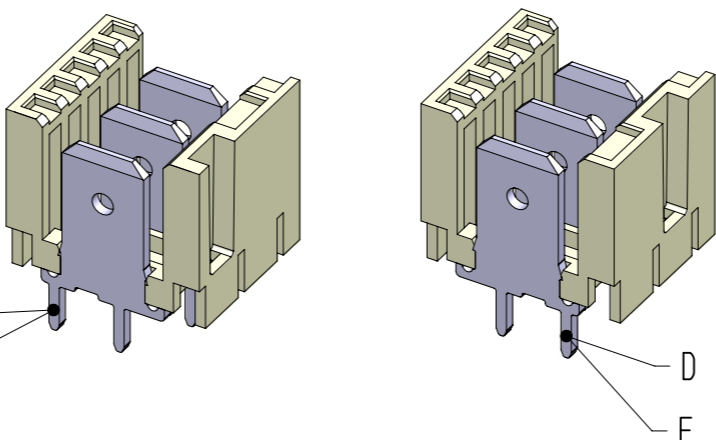
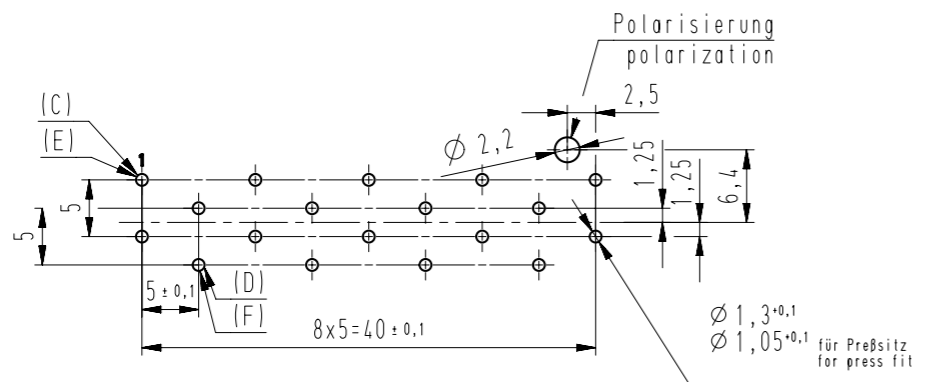

vereinfachte Darstellung einer möglichen Abart
 simplified representation of possible variation

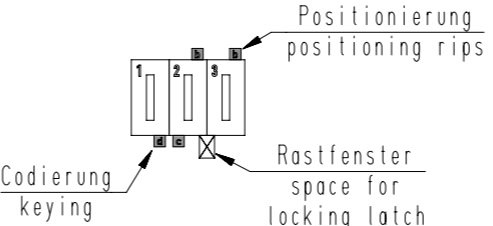

Beispiel Artikelbezeichnung:
 example part description:

MSVV 9401-009-W0A-CCC-MMM-NN

- Farbmarkierung / colour marking
- Beschriftungscode / labeling code
- Material und Farbcode material and colour code
- Abart / variant
- Kontaktcode / contact code
- Polzahl / no. of poles
- Artikel-Nr. / part no.
- Verpackungscode / packing code
- Alpha-Teil der Artikelbezeichnung alpha part of the part description

-VV-		
Verpackungscode / packing code		
VV	Verpackungsart / packaging	Bemerkung / remark
LO	lose, geschüttet / slack pouring	WN 50.202
EM	Einzelmagazine / single magazine	WN 50.202

-W-			
Kontaktcode / contact code			
W	Kontakt Artikel-Nr. / contact part no.	Material / material	Veredelung / plating
0	C = RM 6138.050 P 0,8-6,3 D = RM 6138.050 P 0,8-6,3 180° gedreht / turned	CuZn	Sn
1	E = RM 6138.001 P 0,8-6,3 F = RM 6138.001 P 0,8-6,3 180° gedreht / turned	CuZn	Ag

Artikelbezeichnung part description	Anzahl der Kontakte number of contacts	Bestückung / loading									Codierungsvariante siehe Tabelle see chart MH 8420-009	Rastfenster zwischen den Kammern space for locking latch between chambers Bemerkung / remark
		1	2	3	4	5	6	7	8	9		
MSVV 9401-009-00A-CCC-MMM-NN	9	C	D	C	D	C	D	C	D	C	0A	1 X
MSVV 9401-009-00D-CCC-MMM-NN	9	C	D	C	D	C	D	C	D	C	0D	1 X 2 X 7 X 8 X
MSVV 9401-009-012-CCC-MMM-NN	9	C	D	C	D	C	D	C	D	C	12	1 X 2 X 3 X 4 X 9
MSVV 9401-009-021-CCC-MMM-NN	9	C	D	C	D	C	D	C	D	C	21	1 X 2 X 4 X 5 X 7 X 8 X
MSVV 9401-009-022-CCC-MMM-NN	9	C	D	C	D	C	D	C	D	C	22	1 X 2 X 3 X 4 X 6 X 8 X
MSVV 9401-009-023-CCC-MMM-NN	9	C	D	C	D	C	D	C	D	C	23	1 X 2 X 3 X 4 X 6 X 7 X
MSVV 9401-009-026-CCC-MMM-NN	9	C	D	C	D	C	D	C	D	C	26	1 X 2 X 3 X 4 X 5 X 8 X
MSVV 9401-009-031-CCC-MMM-NN	9	C	D	C	D	C	D	C	D	C	31	1 X 2 X 3 X 4 X 5 X 7 X 9
MSVV 9401-009-033-CCC-MMM-NN	9	C	D	C	D	C	D	C	D	C	33	1 X 2 X 3 X 4 X 5 X 6 X 8 X 9
MSVV 9401-009-038-CCC-MMM-NN	9	C	D	C	D	C	D	C	D	C	38	1 X 2 X 3 X 4 X 5 X 6 X 7 X 8 X 9
MSVV 9401-009-039-CCC-MMM-NN	9	C	D	C	D	C	D	C	D	C	39	1 X 2 X 3 X 4 X 5 X 6 X 7 X 8 X 9

Artikelbezeichnung part description	Anzahl der Kontakte number of contacts	Bestückung / loading									Codierungsvariante siehe Tabelle see chart MH 8420-009	Rastfenster zwischen den Kammern space for locking latch between chambers Bemerkung / remark
		1	2	3	4	5	6	7	8	9		

-CCC-			
Material und Farbcode material and colour code			
Materialinformation siehe Kundenzeichnung material data see customer drawing			
Leergehäuse / housing: MH 9401-...			
WN 14.0617.01 (PA66-GF25)	WN 14.0634.01 (PA66-GF25)		
Code-Nr. code no.	Farbe colour	Code-Nr. code no.	Farbe colour
118	zinkgelb / zinc yellow	960	natur / nature
121	ropsgelb / rope yellow		
314	altrosa / antique pink		
512	lichtblau / light blue		
518	türkisblau / turquoise blue		
605	moosgrün / moss green		
701	silbergrau / silver grey		
905	schwarz / black		
960	natur / nature		

-MMM-		
Beschriftungscode nach Kundenwunsch labeling code acc. to the customer		
Code-Nr. code no.	siehe WN see WN	Farbe colour
000	-----	ohne Beschriftung without labeling
V**	30.79	Standard / standard

-NN-	
Code-Nr. für Farbmarkierung siehe WN 30.83 code no. for colour marking see WN 30.83	
Code-Nr. / code no.	Farbe / colour
00	ohne / without

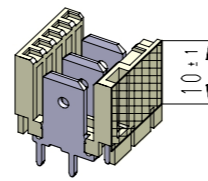

Farbkennzeichnungsbereich bei versilberten Kontakten
 colour coding area when silvered contacts
 (nach / according WN 30.70
 Bereich / area "D")

14	Material WN 14.0634.01 mit Materialcode -960- hinzu.	04.03.22	U0013643
13	Material und Farbcode 627, 715, 721 ungültig und 121 hinzu	11.09.20	U0013643
Index	Änderung / modification		Name
	Datum / date	Name / name	Projektleiter / project manager
erstellt / prepared	25.03.03	U0013643	D.M.
MSVV 9401-009			

Diese Zeichnung darf ohne unsere Genehmigung weder vervielfältigt, noch dritten Personen zugänglich gemacht werden und bleibt unser Eigentum. Zuwiderhandlung ist strafbar.
 All rights strictly reserved. Reproduction or issue to third parties in any form whatever is not permitted without written authority from the proprietor. Violation is punishable.

Gesamte und digital verteilte Zeichnungen benötigen zur Freigabe keine Unterschrift!
 Scanned and digitally distributed drawings do not need a signature for the release!

Technische Änderungen vorbehalten!
 Technical modifications will be reserved.

Verteiler distributor
 Empfänger receiver
 SDH
 SDW