

Diese Zeichnung darf ohne unsere Genehmigung weder vervielfältigt, noch dritten Personen zugänglich gemacht werden und bleibt unser Eigentum. Zuwiderhandlung ist strafbar.
All rights strictly reserved. Reproduction or issue to third parties in any form whatsoever is not permitted without written authority from the proprietor. Violation is punishable.

Gesamte und digital verteilte Zeichnungen benötigen zur Freigabe keine Unterschrift!
Scanned and digitally distributed drawings do not need a signature for the release!

Technische Änderungen vorbehalten!
Technical modifications will be reserved.

Verteiler distributor
Empfänger receiver
SDH
SDW

ECO-DOMO NF (RAST 5) Federgehäuse in Schneidklemmtechnik - passive Innenverrastung (Rastnocken)
ECO-DOMO NF (RAST 5) IDC housings - passive inside locking (locking cam)

Raster: / pitch: 5mm
Identifikator: / identification: MFVV_9562-002_A_KF
Blatt: / page: A

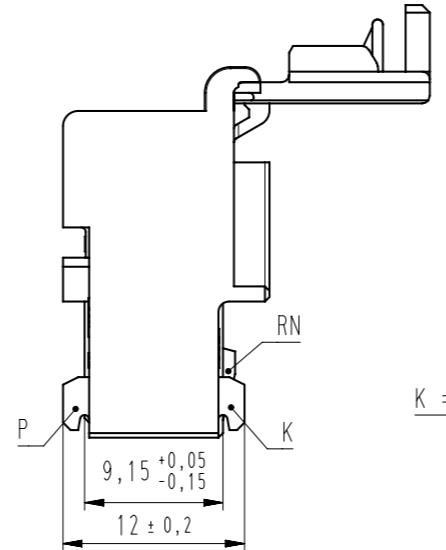
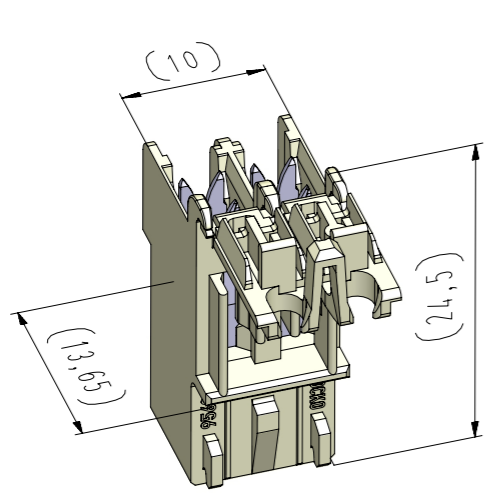

vereinfachte Darstellung einer möglichen Abart
simplified representation of possible variation

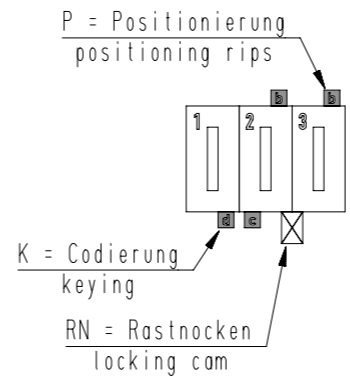

Beispiel Artikelbezeichnung:
example part description:

MFVV 9562-002-W80-CCC-MMM-NN

Fehlende Maße und Hinweise siehe separate Kundenzeichnung
Missing dimensions and notes see separate customer drawing



- Farbmarkierung / colour marking
- Beschriftungscode / labeling code
- Materialcode / material code
- Abart / variant
- Kontaktcode / contact code
- Polzahl / no. of poles
- Artikel-Nr. / part no.
- Verpackungscode / packing code
- Alpha-Teil der Artikelbezeichnung
alpha part of the part description

Artikelbezeichnung part description	Anzahl der Kontakte number of contacts	Bestückung / loading										Gehäuserohling siehe Tabelle empty housing see chart MH 8420-002	X = Rastnocken zwischen den Kammern locking cam between chambers MH 8420-OXX C	Codierungsvariante siehe Tabelle coding peg variant see chart MH 8420-002	Bemerkung remark	
		1	2													
MFVV 9562-002-W80-CCC-MMM-NN	2	W	W									80	X	80	Grundcodierung Rohling basic coding empty housing	
MFVV 9562-002-W99-CCC-MMM-NN	2	W	W									99		99	Grundcodierung Rohling basic coding empty housing	
MFVV 9562-002-W0A-CCC-MMM-NN	2	W	W									80	X	0A		
MFVV 9562-002-W0B-CCC-MMM-NN	2	W	W									80	X	0B		
MFVV 9562-002-W0C-CCC-MMM-NN	2	W	W									80	X	0C		
MFVV 9562-002-W0D-CCC-MMM-NN	2	W	W									80	X	0D		
MFVV 9562-002-W0E-CCC-MMM-NN	2	W	W									80	X	0E		
MFVV 9562-002-W0F-CCC-MMM-NN	2	W	W									80	X	0F		
MFVV 9562-002-W0G-CCC-MMM-NN	2	W	W									80	X	0G		
MFVV 9562-002-W0I-CCC-MMM-NN	2	W	W									80	X	0I		
MFVV 9562-002-W0K-CCC-MMM-NN	2	W	W									80	X	0K		
MFVV 9562-002-W0M-CCC-MMM-NN	2	W	W									80	X	0M		
MFVV 9562-002-W0N-CCC-MMM-NN	2	W	W									80	X	0N		
MFVV 9562-002-W0O-CCC-MMM-NN	2	W	W									80	X	0O		
MFVV 9562-002-W0Q-CCC-MMM-NN	2	W	W									80	X	0Q		

-VV-	
Verpackungscode / packing code	
VV	Verpackungsart / packaging
MP	Magazinpaket / magazine parcel
MG	Magazingroßverpackung / large magazine parcel

-W-		
Kontaktcode / contact code		
W	Stromstärke amperage	Kabel- Querschnitt cable section
8	16A	0,35 bis 1,5 mm ²

-MM-		
Beschriftungscode nach Kundenwunsch labeling code acc. to the customer		
Code-Nr. code no.	siehe WN see WN	Farbe colour
000	----	ohne Beschriftung without labeling
N**	30.72	Standard standard

-CCC-			
Material und Farbcode material and colour code			
Materialinformation siehe Kundenzeichnung material data see customer drawing			
Leergehäuse / housing: MH 9562-...			

WN 14.0617.01 (PA66-GF25) WN 14.0634.01 (PA66-GF25)			
Code-Nr. code no.	Farbe colour	Code-Nr. code no.	Farbe colour
118	zinkgelb zinc yellow	960	natur nature
314	altrosa antique pink		
512	lichtblau light blue		
518	türkisblau turquoise blue		
605	moosgrün moos green		
701	silbergrau silver grey		
960	natur nature		

-NN-	
Farbmarkierung siehe colour marking see WN 30.83	
Code-Nr. code no.	Farbe colour
00	ohne without

23	Material WN 14.0634.01 mit Materialcode -960- hinzu.	04.03.22	U0013643
22	Material WN 14.0632.01 entfernt	07.07.21	U0013643
Index index		Änderung / modification	
	Datum date	Name name	Projektleiter project manager
	02.03.06	U0013643	D.M.
			MFVV 9562-002